

# 2500553.1



Please read all instructions carefully before use and retain for future reference.  
Veuillez lire attentivement ces instructions avant utilisation et conservez-les pour pouvoir les consulter à l'avenir.  
Bitte lesen Sie die Anleitung sorgfältig und bewahren Sie sie als Referenz auf.  
Leed todas las instrucciones detenidamente antes de usar y retened para futuras consultas.  
Si prega di leggere attentamente tutte le istruzioni prima dell'uso e conservarle per una futura consultazione.



Ensure product is not damaged before first use  
S'assurer que le produit n'est pas endommagé avant la première utilisation  
Stellen Sie vor dem ersten Gebrauch sicher, dass das Produkt nicht beschädigt ist  
Asegúrese de que el producto no esté dañado antes del primer uso  
Assicurarsi che il prodotto non sia danneggiato prima del primo utilizzo

**WARNING:** Do not use the oven in a confined and/or habitable space e.g. houses, tents, caravans, motor homes, boats.  
! Danger of carbon monoxide poisoning fatality !



**CAUTION** Do not immerse in water.  
**ATTENTION** Ne pas immerger dans l'eau.  
**VORSICHT** Nicht in Wasser tauchen.  
**PRECAUCIÓN** No sumergid en agua.  
**AVVERTENZA** Non immergere nell'acqua.



Do not cover.  
Ne pas couvrir.  
Nicht abdecken.  
No cubrir.  
Non coprire.



**CAUTION** hot surfaces  
**ATTENTION** Surfaces chaudes  
**VORSICHT** heiße Oberflächen  
**PRECAUCIÓN** superficies calientes  
**AVVERTENZA** Superfici calde



**20min**

Estimated assembly time  
Temps d'assemblage estimé  
Geschätzte Montagezeit  
Tiempo Estimado de Ensamblaje  
Tempo stimato per il montaggio



**WARNING! NEVER** leave a fire unattended and keep children and pets well away when ignited.  
**ATTENTION!** Ne laissez **JAMAIS** un feu sans surveillance et gardez les enfants et les animaux domestiques à l'écart lorsqu'ils sont enflammés.  
**WARNUNG! NIEMALS** ein Feuer unbeaufsichtigt lassen und Kinder und Haustiere fernhalten, wenn sie entzündet werden.  
**¡ADVERTENCIA! NUNCA** deje un fuego desatendido y mantenga a los niños y mascotas alejados cuando se enciende.  
**AVVERTIMENTO!** Non lasciare MAI il fuoco incustodito e tenere lontani i bambini e gli animali domestici quando vengono accesi.



## EN

Please read all instructions carefully before use and retain for future reference.

**INTENDED USE WARNING!** The product is for outdoor use only. **DO NOT** use indoors. This product should **NOT** be used in motor homes, tents, sheds or any similar locations where ventilation is limited. Use only in an uncovered, well ventilated area. Position on a suitable heat-resistant surface such as a concrete patio slab. This product is not intended as a climbing structure and it is not a toy. Children should be supervised to ensure that they do not play with the product. Keep children and pets away from the product at all times when cooling. Flammable materials and heat-sensitive items should be kept away from the product during use and when cooling. Keep loose fitting clothing away and long hair tied back. Do not overload the product.

### IMPORTANT SAFETY INFORMATION

**IMPORTANT:** The product should only be lit by safe means such as firelighters complying with EN1860-3. Pay close attention to all warnings and instructions provided with any lighting equipment/fuels. Always keep a fire extinguisher, garden hose, or bucket of sand nearby to smother the fire if necessary.

**WARNING! DANGER OF CARBON MONOXIDE POISONING.** Do not light this product or let it smoulder or cool down in confined spaces. Do not use under awnings, parasols or gazebos.

This Pellet Pizza Oven is not intended for use by persons with reduced physical, sensory or mental capabilities, or lack of experience and knowledge, unless supervised or given appropriate instruction concerning the product's use by a person responsible for their safety.

### GENERAL PRECAUTION

Do not allow to be used as a toy. Children should be supervised to ensure they do not play with the Pellet Pizza Oven.

If the Pellet Pizza Oven is not functioning properly, has been dropped or damaged, do not use, contact DOMU Brands Customer Services. Do not use the Pellet Pizza Oven if any parts appear to be faulty, missing or damaged. Ensure all parts are securely attached before use.

**NOTE** It is normal, when in use, that the coated metal may discolour due to the heat generated by the burning pellets.  
The surface may darken turning to a chalky or matt finish

### FOOD COOKING INFORMATION

Always wash your hands before and after handling uncooked meats.  
Always keep raw meats away from cooked meats and other foods.  
Before cooking, ensure the grill surfaces and tools are clean and free from old food residue.  
**DO NOT** use the same utensils (not included) to handle cooked and uncooked foods.  
Ensure all meats are thoroughly cooked for eating.

### RISK OF PERSONAL INJURY

**WARNING** When using this product, safety rules must be followed. For your safety and for the safety of bystanders and property, read and understand these instructions before using the Pellet Pizza Oven.  
Do not move the pizza box until it has fully cooled down.

Do not leave unattended while in use and keep young children and pets clear of the barbecue.

Read the installation, operation and maintenance instructions thoroughly before installing or servicing this product. Improper installation, adjustment, alteration or improper or incomplete maintenance can cause damage to property or serious or fatal injury.

Flammable materials and heat-sensitive items should be kept away from the product during use and when cooling.

Always use protective gloves when handling the pizza stone.

Keep loose fitting clothing away and long hair tied back.

Do not overload the Pellet Pizza Oven.

**IMPORTANT** Please ensure that residual fat is regularly cleared from the drip tray. The burning of technique for cleaning may cause a fat fire. This risk is especially high if cooking high fat meats. A fat fire can damage both the pizza box and barbecue which will not be covered under warranty.

**WARNING** To avoid burns, do not touch metal parts of the product until it has completely cooled. Handles will become very hot and unsafe to touch during use, unless you are wearing rated protective gear (pot holders,

thermal proof mittens, hot pad etc). Standard household oven gloves will **NOT** offer sufficient protection and should not be used. Hot embers may be emitted during use

### CLEANING & MAINTENANCE

Allow to cool completely before cleaning.

**CAUTION!** Do not wash the Pizza Stone with soap, as this can be absorbed by the stone and possibly affect the taste of the next pizza you make.  
Wipe the Pizza Stone with a damp cloth to remove any grease. If a deeper clean is required, we recommend using a fine grain sandpaper to remove any tough residue. Wipe and dry immediately after.  
Allow your stone to dry completely (for at least 1-2 hours) before using it again.

Protect from severe weather conditions. We recommend that you use a cover to protect this item when not in use.

**CAUTION** The Pellet Pizza Oven must be completely cool before covering or storing.

Ensure you have all the pieces listed. If you are missing

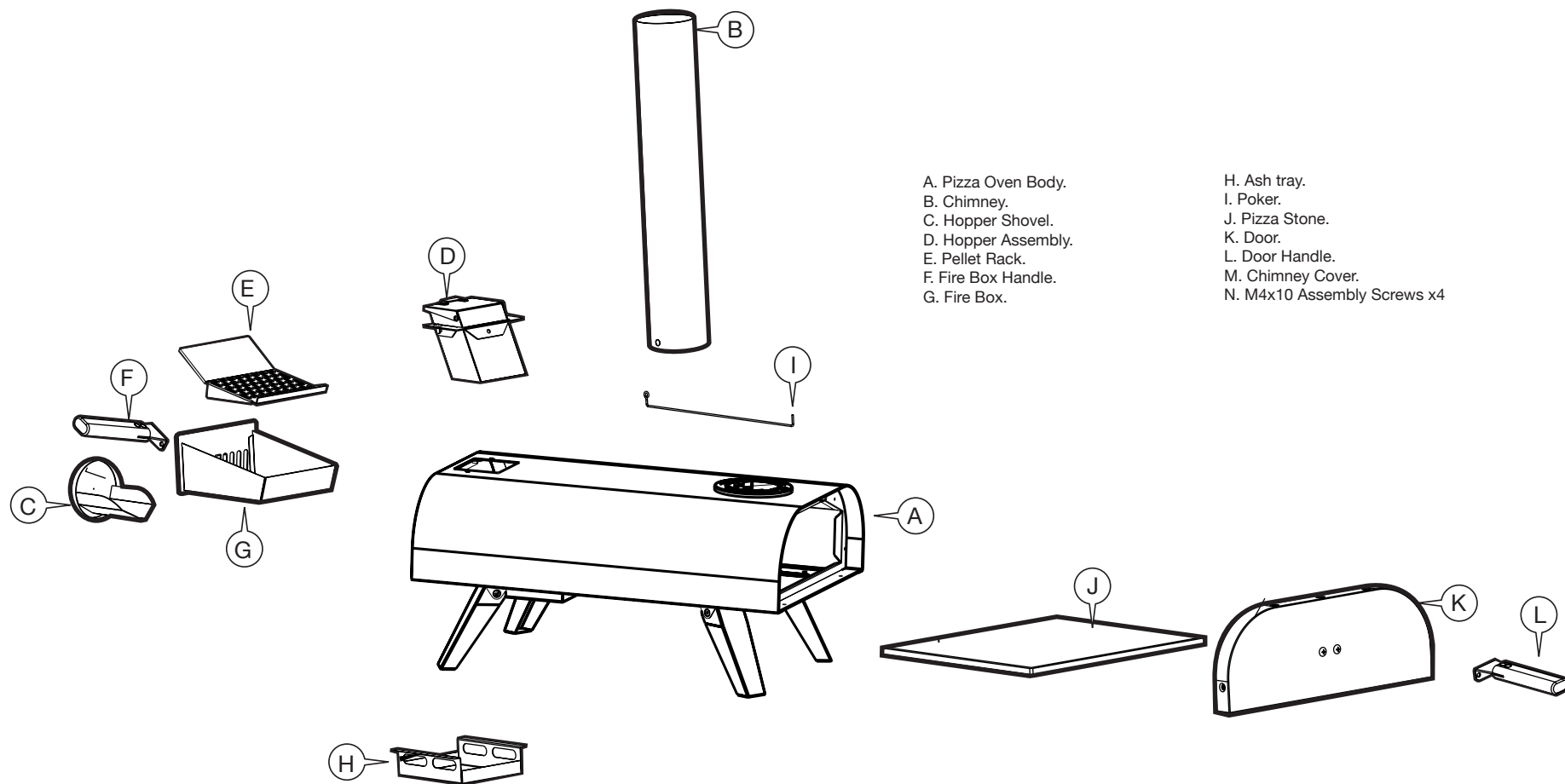

- A. Pizza Oven Body.
- B. Chimney.
- C. Hopper Shovel.
- D. Hopper Assembly.
- E. Pellet Rack.
- F. Fire Box Handle.
- G. Fire Box.

- H. Ash tray.
- I. Poker.
- J. Pizza Stone.
- K. Door.
- L. Door Handle.
- M. Chimney Cover.
- N. M4x10 Assembly Screws x4

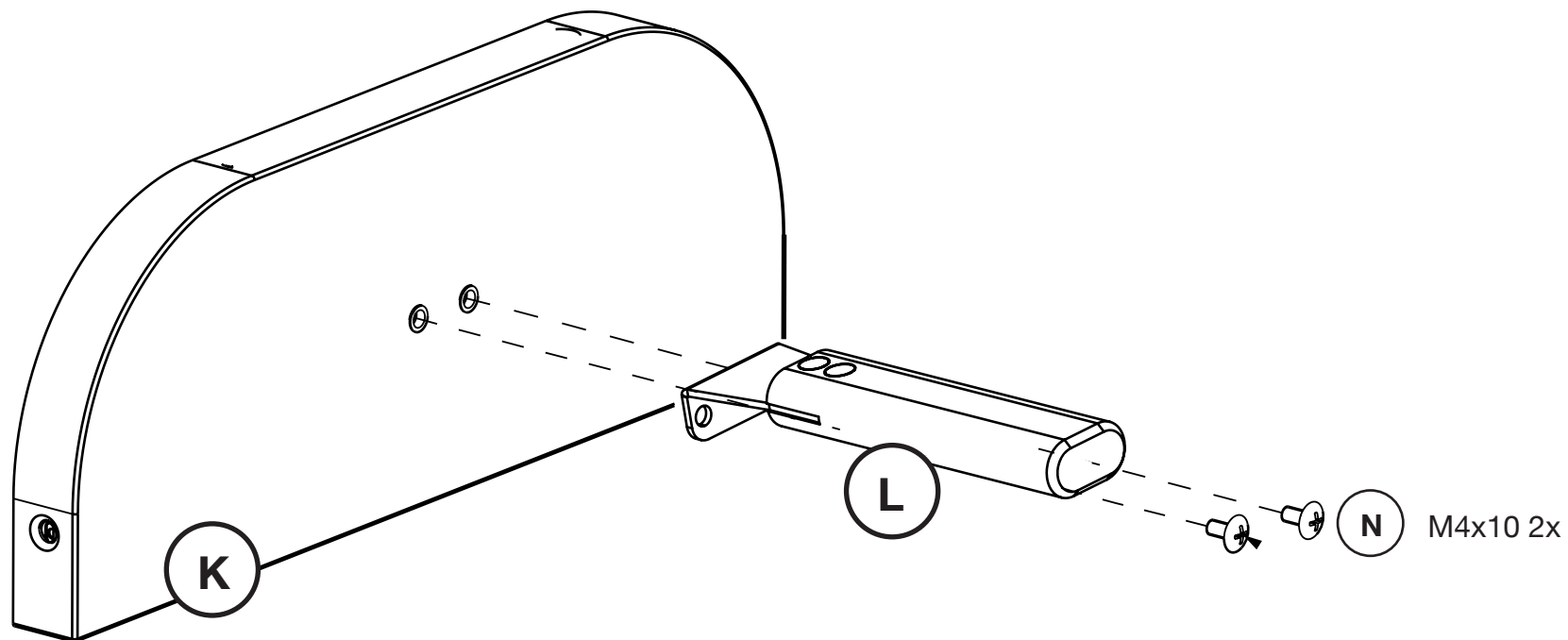

Unfold all of the legs (pre-attached).

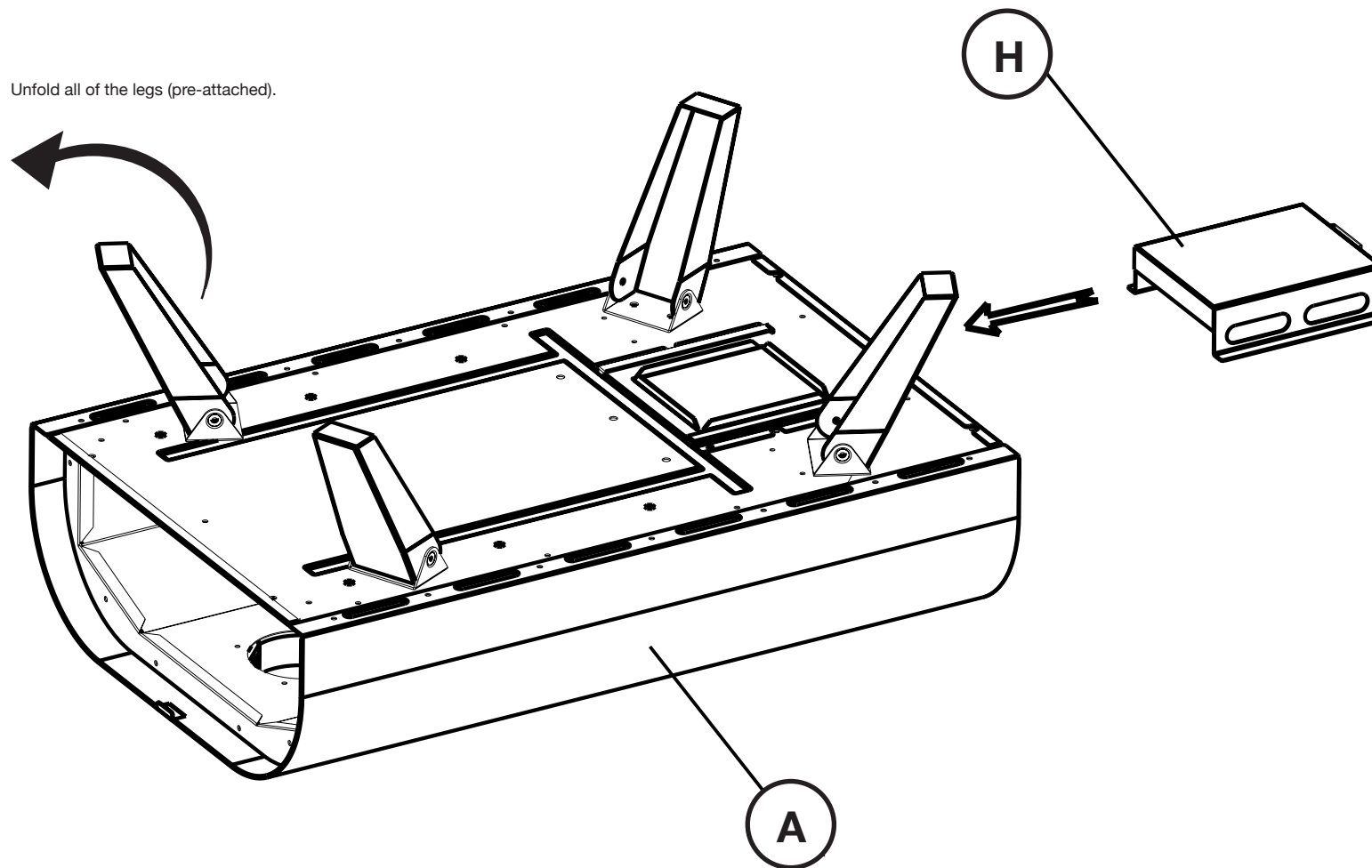

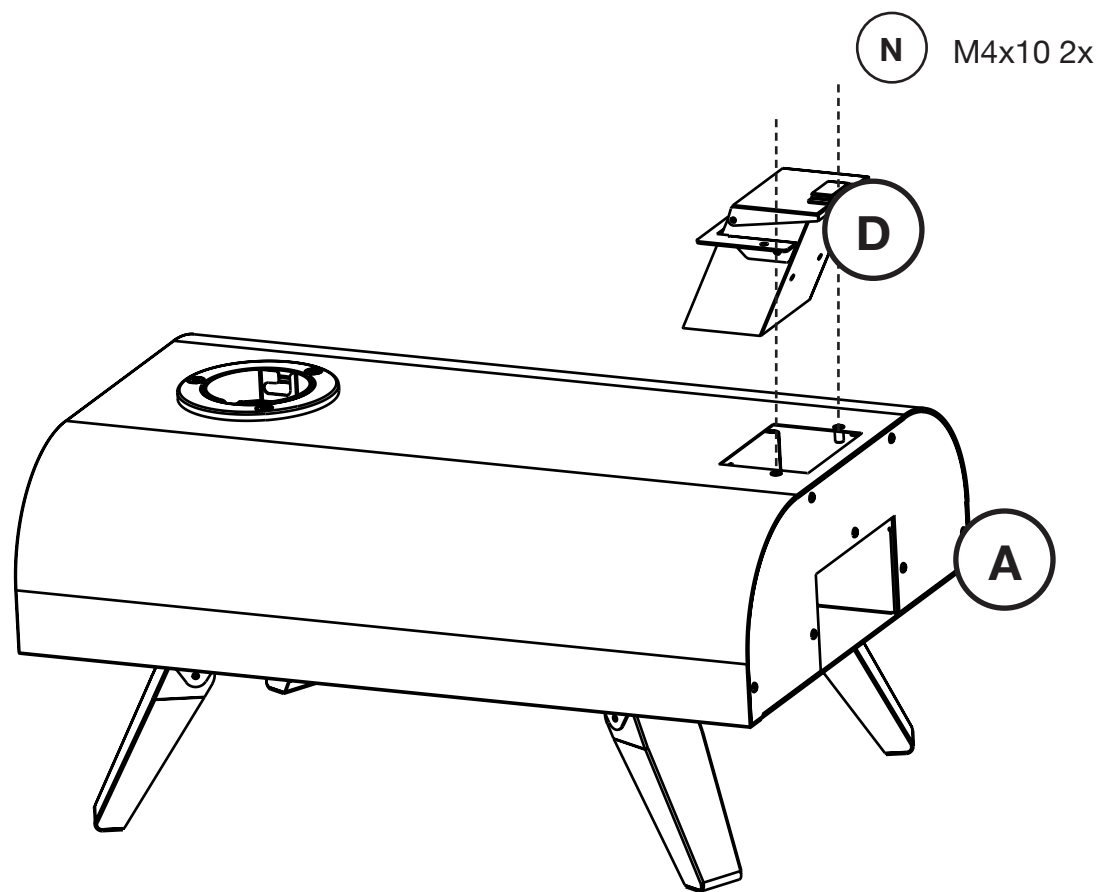

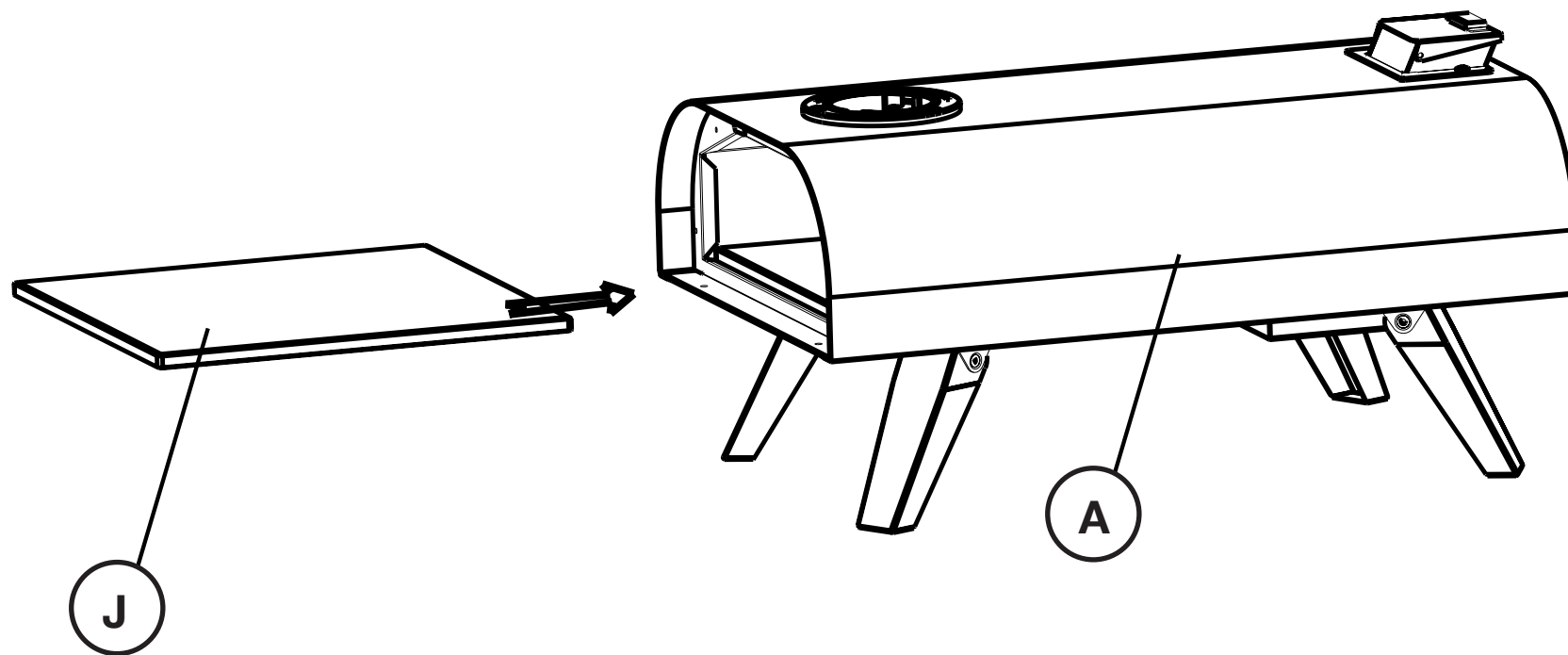

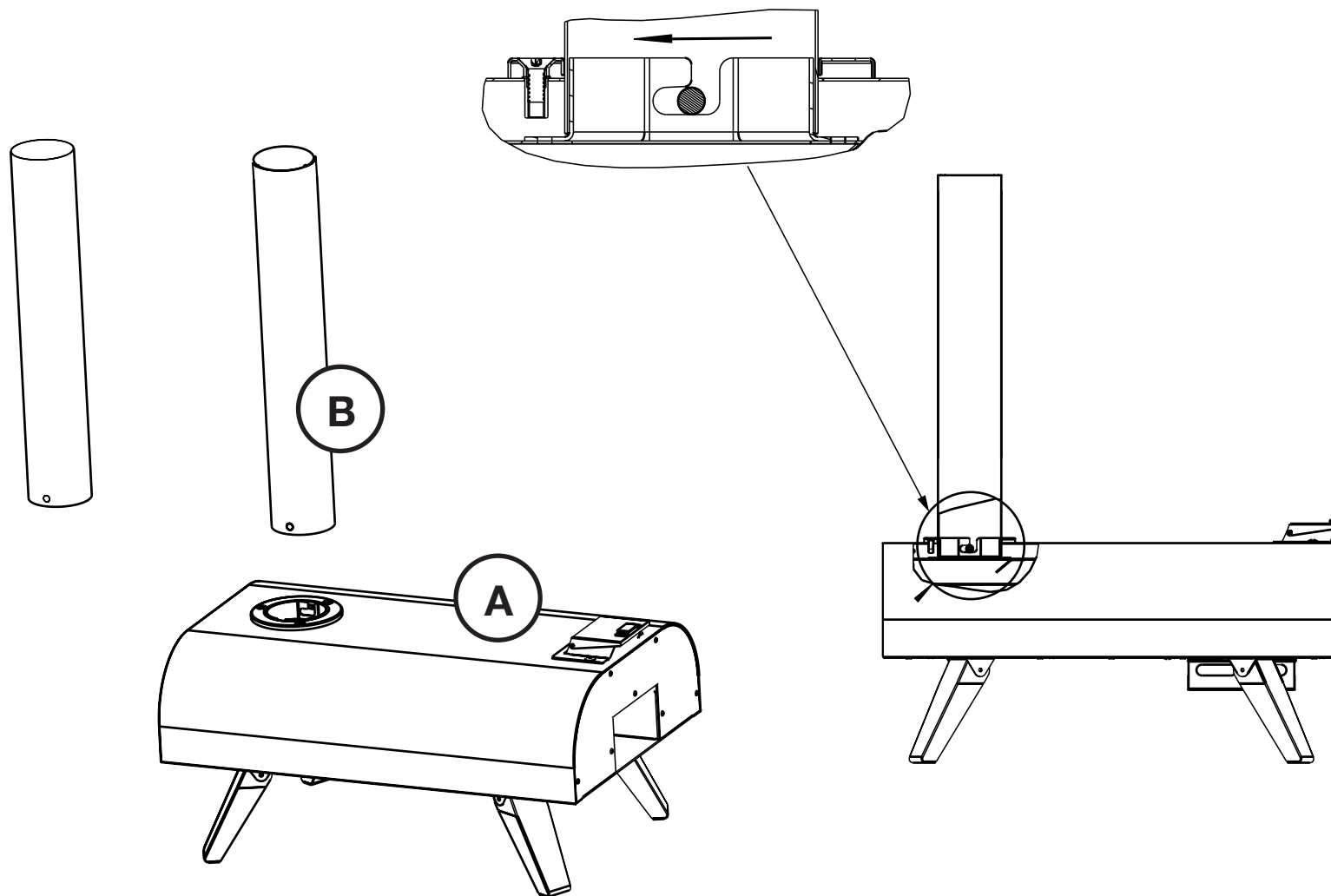



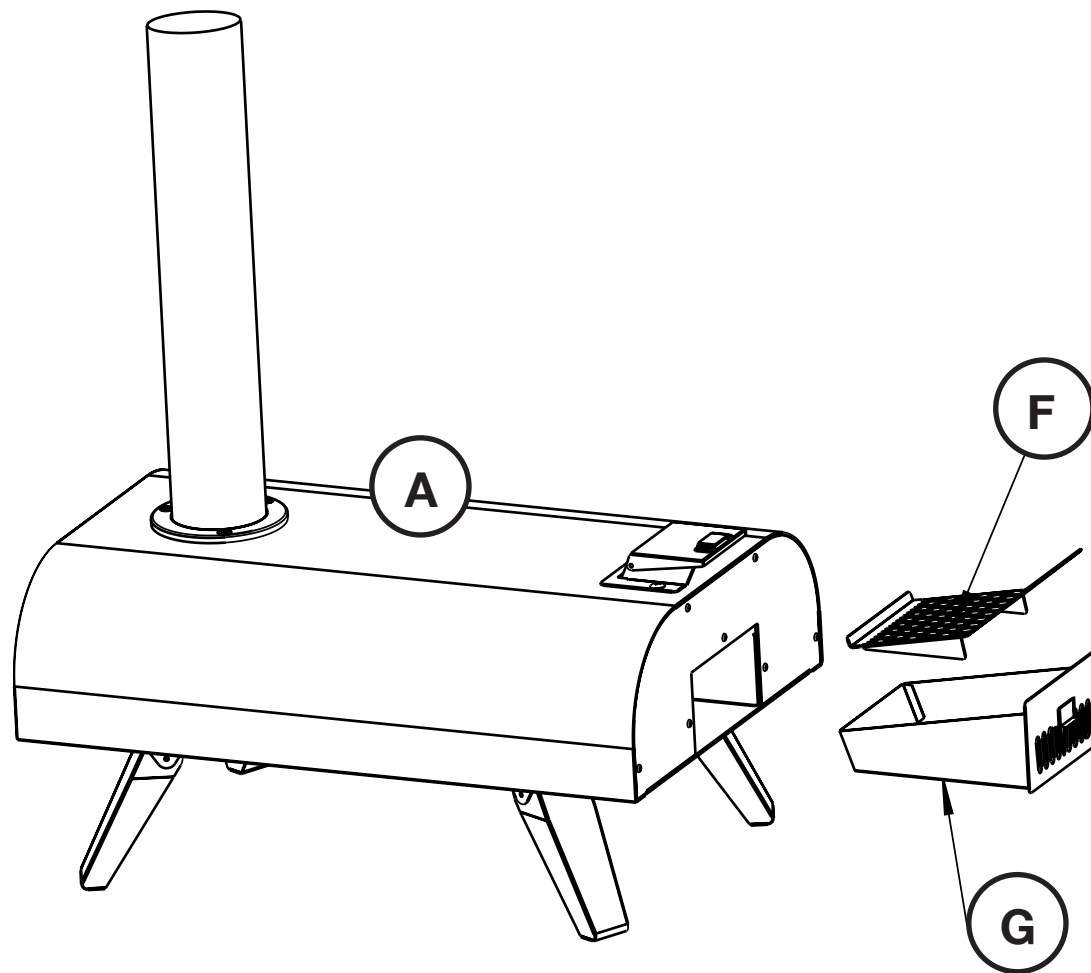

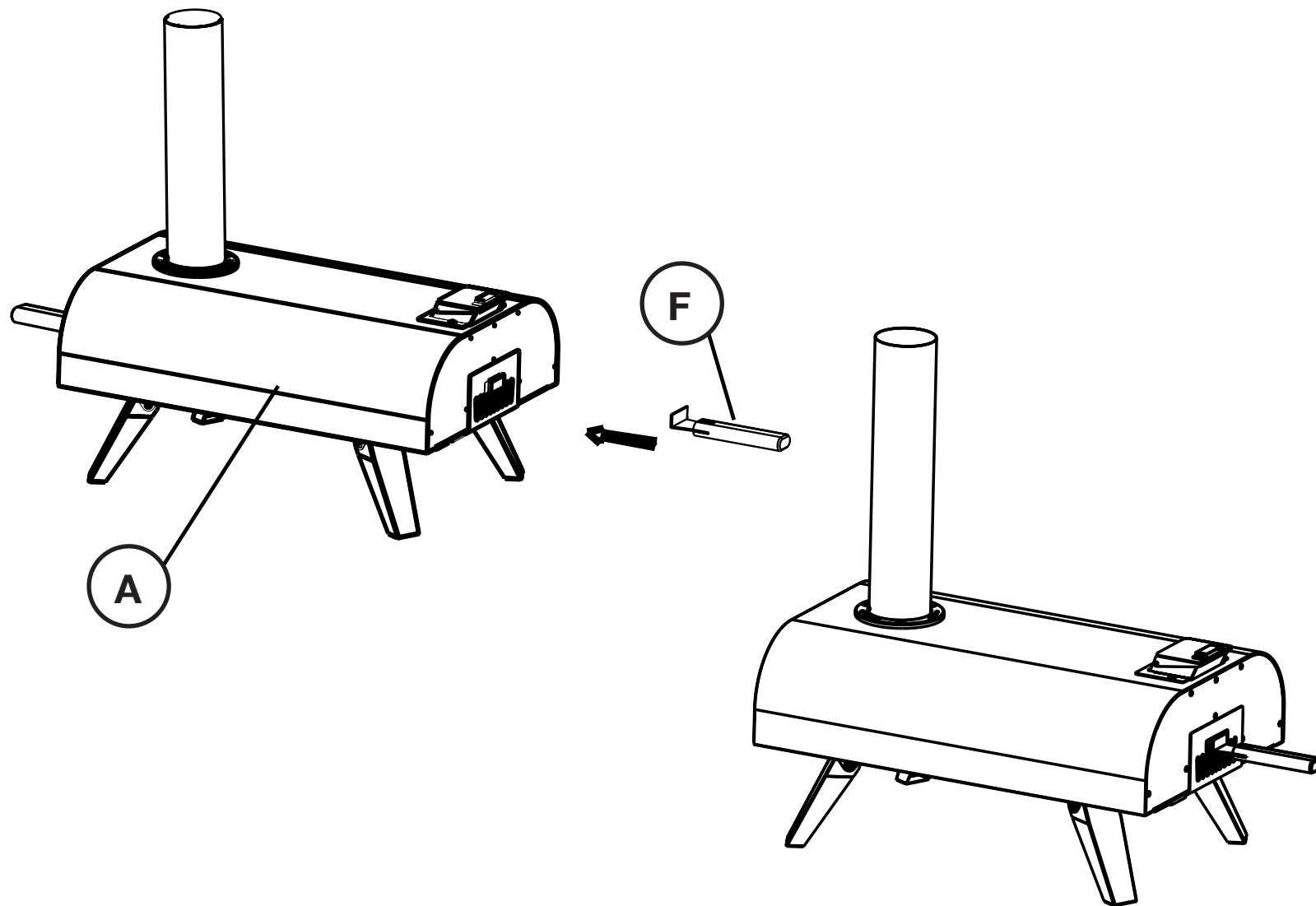

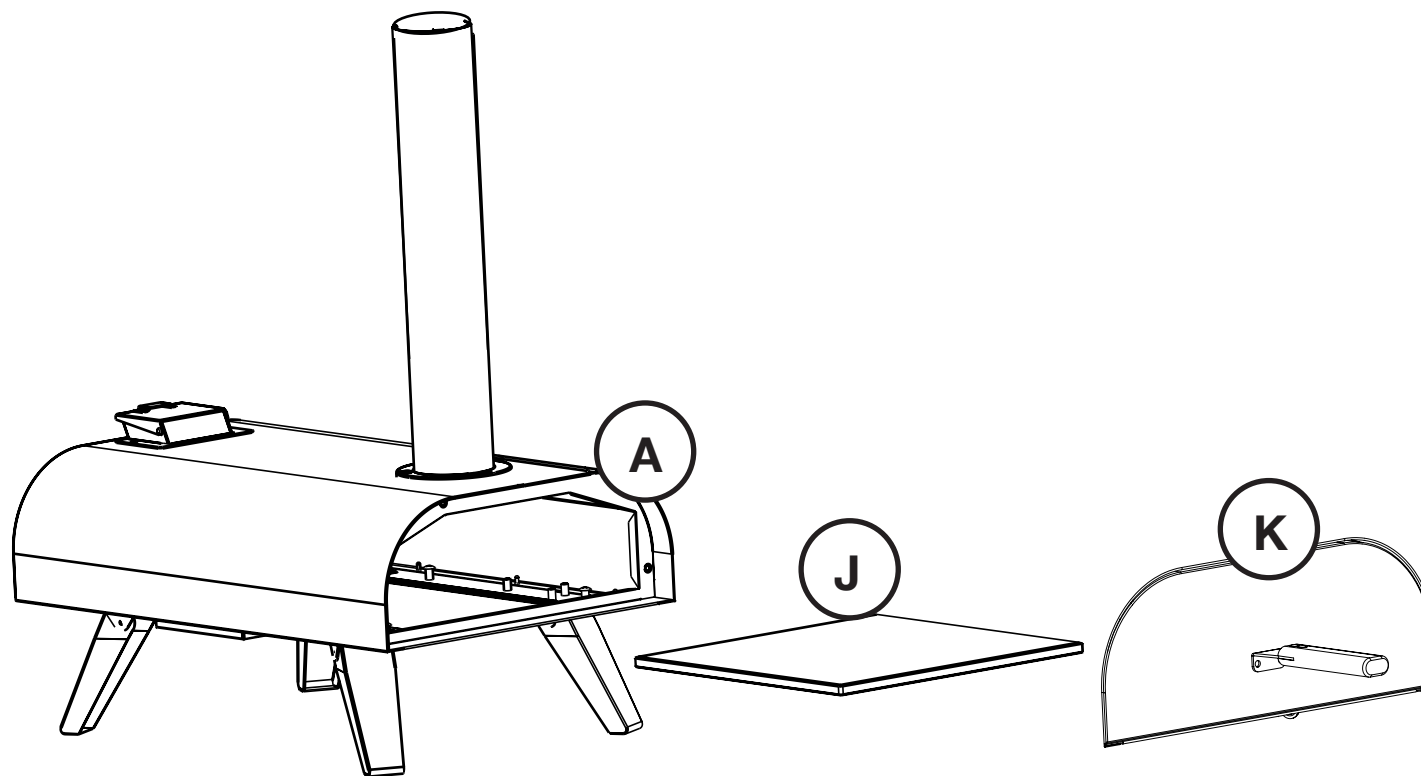

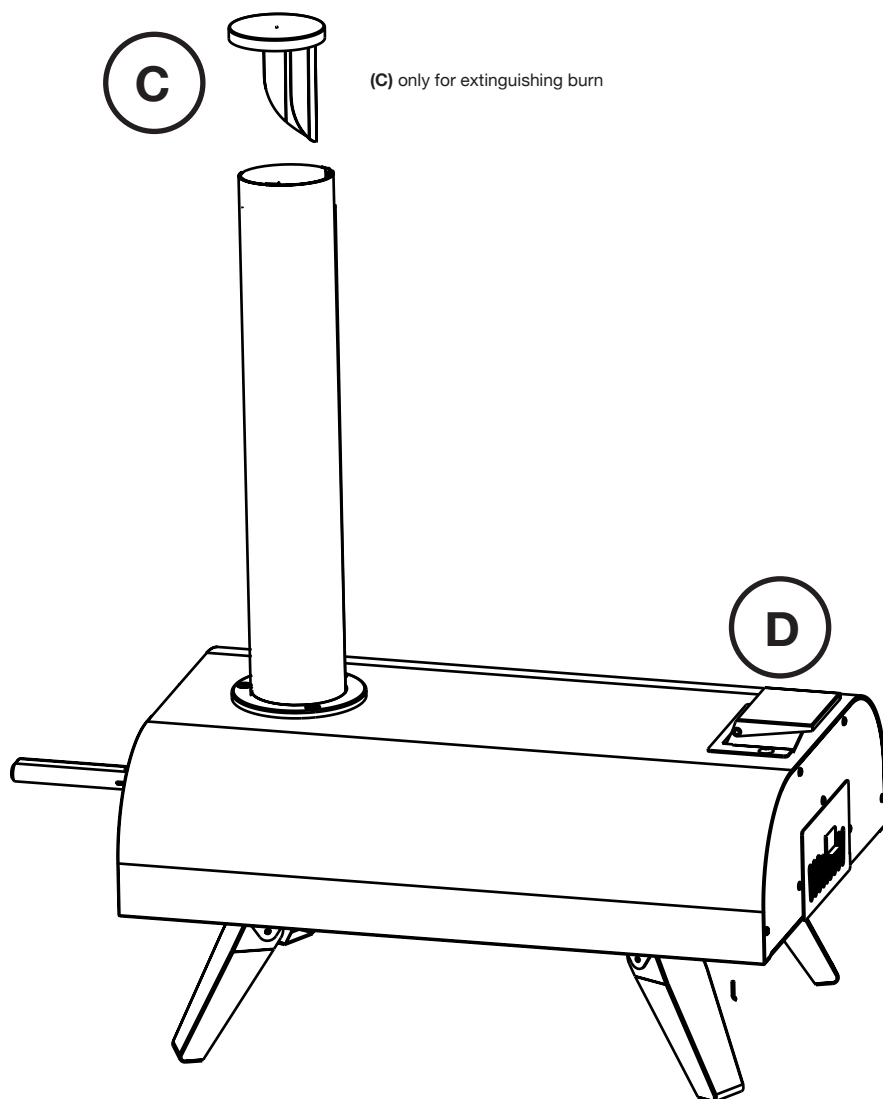

(C) only for extinguishing burn

Set the Pizza Oven up in a suitable position, on a flat, stable surface away from any combustible items.

Place pellets (recommended 600g not supplied) on the Pellet Rack (E) and ignite using natural wood firelighters. This may take around 15-20 seconds until fully ignited.

Close the front door (K) to allow the oven to pre-heat. We advise to temperature and pellet check at 5 minute intervals. Temperature check with a suitable Thermal Measurement Gun. To replenish pellets, use the Hopper Shovel (C) to take some pellets and pour them onto the Pellet Rack through the Hopper Assembly (D).

**NOTE** You will be required to top up with pellets before the optimum temperature of 400c is reached.

Once at 400c Place your pizza on the Pizza Stone (J) and place inside the Pizza Oven and close the door (K) securely.

**CAUTION!** Wear heat-resistant mitts/gloves when handling any part of the Pizza Oven during use. The surface are very hot and will cause burning injuries if touched with bare hands.

#### CLEANING & MAINTENANCE

Once the cooking process is complete and you are ready to extinguish any remaining flames, remove the Ash Tray/Pellet rack using the Fire Stick (14) and douse with water.

**CAUTION!** Take extra care as they may still be very hot.

Once the Pizza Oven has completely cooled, you can clean the fats/oils from inside using hot and soapy water with a non-abrasive cleaning pad. This will help remove any stubborn foods

**DO NOT** clean your Pizza Stone using a dishwasher. Clean by hand only using the instructions stated at the front of this manual.

When the Pizza Oven is not in use during the winter months, it is highly recommended you cover using a suitable weather-proof sheet or store in a dry place away from any harsh weather conditions. Leaving the Oven out in the rain may cause the item to rust.

#### BAKING

Once at 400c Place your pizza on the Pizza Stone (J) and place inside the Pizza Oven and close the door (K) securely.

**NOTE!** Due to the high temperature of the Oven, pizzas will typically take no longer than 90 seconds to cook. Ensure you check regularly and rotate the pizza. Avoid leaving unattended.

Rotate the pizza 90 degrees with pizza peel or baking tools, then close the door to bake. Repeat the same process until the pizza is rotated and baked 360 degrees.

**IMPORTANT!** When the pellet fuel in the pizza oven is burning, the door must be closed unless food needs to be put in or taken out.

This is to prevent too much air coming in from the oven door, which may cause heavy smoke inside the fire box assembly (E&G) and hopper assembly (D). Always operate the door with provided handle.





## EN

**DISPOSAL INFORMATION** Please recycle where facilities exist. Check with your local authority for recycling advice.

**CUSTOMER SERVICE** If you are having difficulty using this product and require support, please contact [support@domu.co.uk](mailto:support@domu.co.uk)

**WARRANTY** To register your product and find out if you qualify for a free extended warranty please go to [www.vonhaus.com/warranty](http://www.vonhaus.com/warranty). Please retain a proof of purchase receipt or statement as proof of the purchase date. The warranty only applies if the product is used solely in the manner indicated in the warnings page of this manual, and all other instructions have been followed accurately. Any abuse of the product or the manner in which it is used will invalidate the warranty. Returned goods will not be accepted unless re-packaged in its original packaging and accompanied by a relevant and completed returns form. This does not affect your statutory rights. No rights are given under this warranty to a person acquiring the appliance second-hand or for commercial or communal use.

**COPYRIGHT** All material in this instruction manual are copyrighted by DOMU Brands. Any unauthorised use may violate worldwide copyright, trademark, and other laws.

## FR

### INFORMATIONS RELATIVES AU RECYCLAGE

Veuillez recycler là où il existe des installations adéquates. Vérifiez auprès de vos autorités locales pour obtenir des conseils sur le recyclage.

**SERVICE CLIENT** Si vous rencontrez des difficultés pour utiliser ce produit et avez besoin d'assistance, veuillez contacter [support@domu.co.uk](mailto:support@domu.co.uk)

**GARANTIE** Pour enregistrer votre produit et découvrir si vous vous qualifiez pour une extension gratuite de garantie, rendez-vous sur [www.vonhaus.com/warranty](http://www.vonhaus.com/warranty). Conservez une preuve d'achat, reçu ou attestation, pour prouver la date de l'achat. La garantie ne s'applique que si le produit a été utilisé de la manière indiquée dans la section de la page des avertissements de ce manuel et que toutes les instructions ont été suivies de manière précise. Tous les abus réalisés sur le produit, dans la manière dont il a été utilisé, rendront la garantie caduque. Les marchandises renvoyées ne seront acceptées que si elles sont remballées dans leur emballage d'origine et accompagnées d'un formulaire de retour adéquat et rempli. Ceci n'affecte pas vos droits statutaires. Cette garantie n'accorde aucun droit à une personne obtenant le produit de seconde main ou à des fins d'utilisation commerciale ou communale.

**DROITS D'AUTEUR** Toutes les informations de ce manuel d'utilisation sont protégées par droit d'auteur par DOMU Brands. Toute utilisation non autorisée pourrait enfreindre les lois mondiales de droit d'auteur, de marque déposée ainsi que d'autres lois.

## DE

**ENTSORGUNG** Bitte entsorgen Sie das Produkt an geeigneten Entsorgungsstellen. Fragen Sie bei Ihrer Gemeinde nach.

**KUNDENSERVICE** Wenn Sie Schwierigkeiten mit diesem Produkt haben und Unterstützung benötigen, wenden Sie sich bitte an [support@domu.co.uk](mailto:support@domu.co.uk)

**GARANTIE** Um Ihr Produkt zu registrieren und zu erfahren, ob eine kostenlose verlängerte Garantie möglich ist, gehen Sie bitte auf [www.vonhaus.com/warranty](http://www.vonhaus.com/warranty). Bitte behalten Sie eine Rechnung oder den Kassenzettel als Nachweis des Einkaufsdatums auf. Die Garantie gilt nur, wenn das Produkt nur wie in dieser Anleitung beschrieben verwendet wurde und wenn alle Anweisungen befolgt wurden. Jeglicher Missbrauch des Produkts oder der Art und Weise, in der es verwendet wird, macht die Garantie ungültig. Zurückgegebene Artikel werden nur akzeptiert, wenn sie sich in der Originalverpackung befinden und wenn ein relevantes und vollständig ausgefülltes Rücksendeformular enthalten ist. Dies betrifft nicht Ihre gesetzlichen Ansprüche. Für Artikel, die gebraucht erworben wurden, oder die kommerzielle oder gemeinschaftlich genutzt werden, entstehen keinerlei Ansprüche auf Garantie.

**COPYRIGHT** Alle Materialien in dieser Anleitung stehen unter Copyright von DOMU Brands Ltd. Jede unautorisierte Verwendung kann das weltweite Copyright, die Handelsmarke und andere Gesetze verletzen.

## ES

**INFORMACION DE DESECHO** Por favor, reciclad en las instalaciones correspondientes. Consultad con vuestra autoridad local para obtener consejos de reciclaje.

**SERVICIO AL CLIENTE** Si tiene dificultades para utilizar este producto y necesita asistencia, contacte con [support@domu.co.uk](mailto:support@domu.co.uk)

**GARANTÍA** Para registrar vuestro producto y averiguar si califica para una garantía extendida gratuita, vaya a [www.vonhaus.com/warranty](http://www.vonhaus.com/warranty). Conservad un comprobante de recibo de compra o extracto como prueba de la fecha de compra. La garantía solo se aplica si el producto se utiliza únicamente de la manera indicada en la página de advertencias de este manual, y todas las demás instrucciones se han seguido con precisión. Cualquier abuso del producto o la manera en que se use invalidará la garantía. Los productos devueltos no se aceptarán a menos que se vuelvan a empaquetar en su embalaje original y acompañados por un formulario de devolución completo y pertinente. Esto no afecta sus derechos legales. No se otorgan derechos bajo esta garantía a una persona que adquiere el aparato de segunda mano o para uso comercial o comunitario.

**DERECHOS DE AUTOR** Todo el material en este manual de instrucciones está protegido por DOMU Brands. Cualquier uso no autorizado puede violar los derechos de autor, marcas comerciales y otras leyes en todo el mundo.

## IT

**INFORMAZIONI SULLO SMALTIMENTO** Si prega di riciclare nelle apposite strutture. Chiedere una consulenza alle autorità competenti per il riciclo.

**SERVIZIO CLIENTI** Se si riscontrano difficoltà nell'utilizzo di questo prodotto e si richiede supporto, contattare [support@domu.co.uk](mailto:support@domu.co.uk)

**GARANZIA** Per registrare il prodotto e capire se hai diritto all'estensione di garanzia, vai su [www.vonhaus.com/warranty](http://www.vonhaus.com/warranty). Si prega di conservare la ricevuta del pagamento quale prova della data d'acquisto. La garanzia si applica solo se il prodotto viene utilizzato esclusivamente come indicato nella pagina delle Avvertenze del presente manuale e se tutte le altre informazioni vengano accuratamente seguite. Qualsiasi abuso nell'utilizzo di questo prodotto invaliderà la garanzia. I resi non saranno accettati se non riposti nella confezione originale ed accompagnati da un modulo di reso completo. Ciò non pregiudica i propri diritti obbligatori. La presente garanzia non attribuisce alcun diritto a coloro che acquistano prodotti di seconda mano o per fini commerciali o condivisi.

**COPYRIGHT** Tutto il materiale contenuto nel presente manuale delle istruzioni è protetto da copyright di DOMU Brands. Qualsiasi uso non autorizzato potrebbe violare il copyright a livello mondiale, marchio ed altre leggi.

## THANK YOU

Thank you for purchasing your product/appliance. Should you require further assistance with your purchase, you can contact us at [support@domu.co.uk](mailto:support@domu.co.uk)  
VonHaus is a registered trademark of DOMU Brands Ltd. Made in China for DOMU Brands. M24 2RW.

## MERCI

Merci d'avoir acheté notre produit/appareil. Si vous aviez besoin d'aide suite à votre achat, vous pouvez nous contacter à [support@domu.co.uk](mailto:support@domu.co.uk)  
VonHaus est une marque déposée de DOMU Brands Ltd. Fabriqué en Chine pour DOMU Brands. M24 2RW.

## VIELEN DANK

Vielen Dank, dass Sie das Produkt/Gerät gekauft haben. Sollten Sie weitere Unterstützung benötigen, können Sie uns gerne unter (email) kontaktieren. [support@domu.co.uk](mailto:support@domu.co.uk)  
VonHaus ist eine registrierte Handelsmarke von DOMU Brands Ltd. Hergestellt in China für DOMU Brands. M24 2RW.

## GRACIAS

Gracias por comprar vuestro producto/aparato. Si requiere asistencia con vuestra compra, podeis contactarnos a [support@domu.co.uk](mailto:support@domu.co.uk)  
VonHaus es una marca registrada de DOMU Brands Ltd. Hecha en China para DOMU Brands. M24 2RW.

## GRAZIE

Grazie per aver acquistato il prodotto. Per ulteriore assistenza sul tuo acquisto, puoi contattarci all'indirizzo email [support@domu.co.uk](mailto:support@domu.co.uk)  
VonHaus è un marchio registrato di DOMU Brands Ltd. Made in Cina per DOMU Brands. M24 2RW.