

2500446



Please read all instructions carefully before use and retain for future reference.



Disconnect appliance from mains before cleaning, maintenance or after a thermal cut out event.



Do not cover.



CAUTION Do not immerse in water.



Do not use outdoors.



Caution Risk of fire R290

Please read all instructions carefully before use and retain for future reference.

INTENDED USE.

This Dehumidifier is for indoor domestic use only. Do not use outdoors or on wet surfaces.

This appliance is not intended for use by persons (including children) with reduced physical, sensory or mental capabilities, or lack of experience and knowledge, unless they have been given supervision or instruction concerning use of the appliance by a person responsible for their safety.

GENERAL PRECAUTIONS.

When using an electrical appliance, basic precautions should always be followed, including the following: Do not allow to be used as a toy. Close attention is necessary when used near children. Children should be supervised to ensure that they do not play with the appliance.

If the appliance is not functioning properly, has been dropped, damaged, left outdoors, or immersed in liquid, do not use, contact DOMU Brands Customer Services. Do not use the appliance if any parts appear to be faulty, missing or damaged.

Ensure all parts are securely attached before using the appliance.

CABLES AND PLUGS.

Check to ensure your electricity supply matches that shown on the rating plate. The appliance must only be used as rated.

Ensure the unit is disconnected from the main outlet before cleaning.

The use of an extension cable is not recommended.

Do not let cord hang over the edge of the table or counter-top where it could be pulled on inadvertently by children or pets, or touch hot surfaces which could damage the cord.

Do not pull the cable around sharp edges or corners.

Keep the cord away from heated surfaces.

Turn off all controls before unplugging.

Do not unplug by pulling on cable. To unplug, grasp the adaptor, not the cable.

Ensure the cable is stored safely to prevent hazards.

The appliance shall be installed in accordance with local/national wire regulations.

If the supply cable is damaged, it must be replaced by a qualified engineer in order to avoid a hazard.

RISK OF PERSONAL INJURY.

Always locate your appliance away from the edge of any worktop, on a firm, flat, heat-resistant surface with sufficient space around all sides.

Ensure that the appliance is at room temperature before operating.

The appliance is not intended to be operated by means of an external timer or separate remote-control system.

When using for the first time, your appliance may give off a 'new' smell and/or smoke. This will dissipate after a few uses.

Keep hair, loose clothing, fingers, and all parts of body away from openings and moving parts.

Do not insert any object into openings or cover the appliance.

Do not obstruct the air inlets/outlets of the appliance.

Do not use in the following locations:-

- Next to a source of fire
- An area where oil is likely to splash
- An area exposed to direct sunlight
- An area where water is likely to splash
- Laundry or wet rooms where the humidity is higher than 85% RH.

- Near a bath, shower or a swimming pool

- In a greenhouse

- An area where flammable gases or liquids are present
Do not dry laundry above the unit to prevent water entering the Dehumidifier.

Do not use in laundry rooms.

Position the unit so the plug is easily accessible.

Do not lift or move the appliance whilst in use.

Do not sit or stand on the unit.

Do not leave the appliance unattended when plugged in. Unplug from outlet when not in use, and before performing user maintenance, connecting or disconnecting attachments or changing accessories.

Do not use means to accelerate the defrosting process.

Do not operate continuously for periods longer than those marked on the product or indicated in the instructions.

Do not lubricate any parts, or carry out any maintenance or repair work other than that shown in this manual, or as advised by the DOMU Brands Customer Services.

Use only as described in this manual and do not exceed maximum capacity (2L).

The appliance shall be stored in a room without continuously operating ignition sources (for example, open flames, gas appliances and electric heaters).

Store so as to prevent mechanical damage from occurring.

Do not pierce or burn.

Be aware that refrigerants may not contain an odour.

The appliance should be installed, operated and stored in a room with a floor area larger than 4m².

The appliance shall be compliant with the national gas regulations.

Servicing shall be performed only as recommended by the manufacturer.

Any person who is involved with working on or breaking into a refrigerant circuit should hold a current, valid certificate from an industry-accredited assessment authority which authorises their competence to handle refrigerants safely in accordance with an industry recognised assessment specification.

Servicing shall only be performed as recommended by the equipment manufacturer. Maintenance and repair requiring the assistance of other skilled personnel, shall be carried out under the supervision of the person competent in the use of flammable refrigerants.

Use only DOMU Brands recommended attachments.

The appliance is filled with flammable gas R290.

Any repairs that are needed, please contact the nearest authorized service centre and strictly follow manufacturer's instructions only.

Failure to follow these instructions will invalidate any warranty.

Energy/Safety protection

Do not cover or restrict the air flow of the inlet/outlet grills.

For maximum performance ensure the minimum distance from walls or objects is be 20cm to ensure air circulation.

Keep filters and grills clean.

When in use do not open windows or doors.

Place the unit of a hard/flat

WARNING FOR DISPOSAL:

It is prohibited to dispose of this appliance in domestic household waste. For disposal there are several possibilities

Do not dispose this product as unsorted municipal waste. Collection of such waste separately for special treatment is necessary.

The municipality has established collection systems, where electronic waste can be disposed of at least free of charge to the user.

The manufacturer will take back the old appliance for disposal at least free of charge to the user.

As old products contain valuable resources.

They can be sold to scrap metal dealers..

Wild disposal of waste in forests and landscapes endangers your health when hazardous substances leak into the ground-water and find their way into the food chain.

Meaning of crossed out wheeled dustbin. Do not dispose of electrical appliances as unsorted municipal waste, use separate collection facilities contact you local government for information regarding the collection systems available if electrical appliances are disposed of in landfills of dumps. Hazardous substances can leak into the groundwater and get into the food-chain, damaging your health and well-being.

The dehumidification capacity is rated at a room temperature of 30°C with a relative humidity of 80%.

If specifications are improved after this pointing, the product nameplate will reflect the new specifications.

The operational temperature is in the range of 7°C to 35°C and Max relative humidity of 80%.

If the room temperature is outside of this range, the unit will not operate normally. GWP value of R290 refrigerant is 3.

TECHNICAL SPECIFICATION

Rated Voltage: 220-240V~

Rated Frequency: 50Hz

Rated Input Power: 200W

Dehumidify Capacity: 12L (30°C, RH80%)

Refrigerant: R290/50g

Permissible Excessive

Operating Pressure:

(Suction) 0.7MPa

(Discharge) 3.2MPa

Max Allowable Pressure: 3.2MPa

COMPONENTS

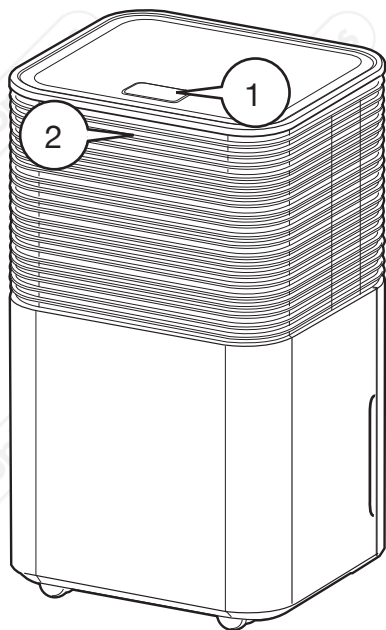

1. Control Panel.
2. 3 Colour Digital Display
3. Carry Handle.
4. Air outlet
5. Air Inlet with Filter.
6. Water Tank.
7. Continuous Drainage hole.
8. Overflow Pipe.
9. Power Supply.

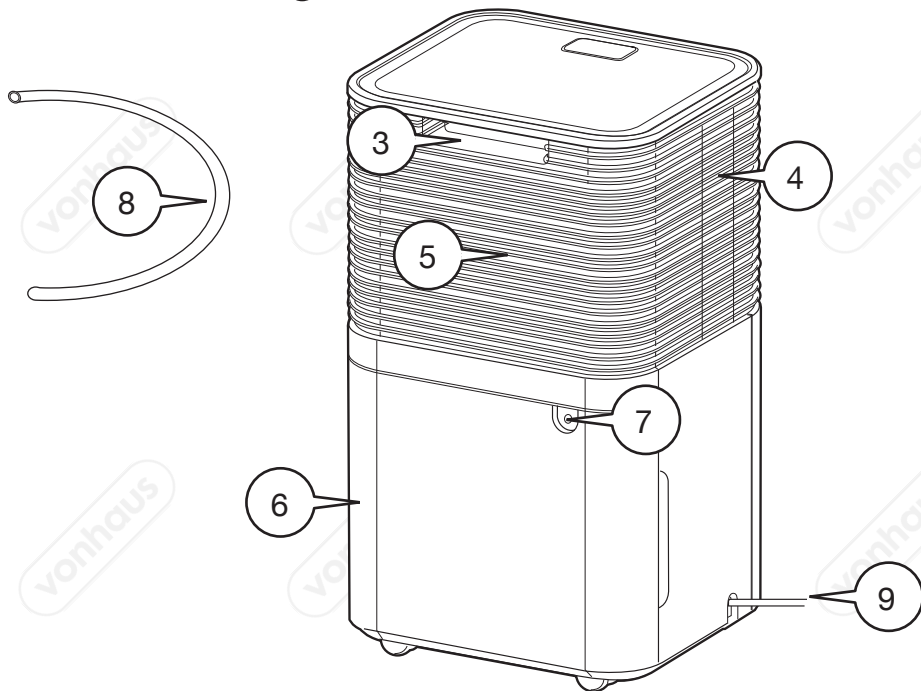

CONTROL PANEL

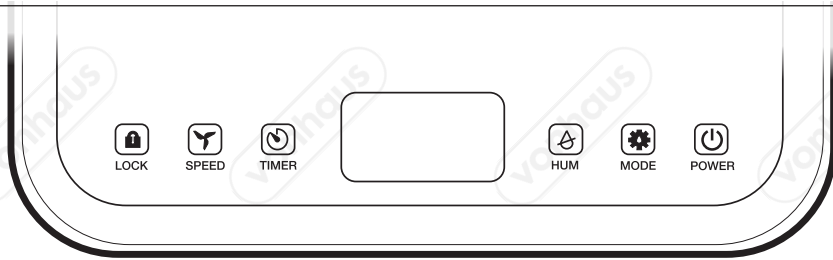

POWER: When the unit is powered on the indicators and LED will display for 1 second after a “buzz” is heard the power indicator will be in standby mode.

Pressing the Power Button will start the unit in default mode the fan will start and the display will indicate the current room humidity and also colour corresponding .

BLUE Ambient Humidity is below 45%

GREEN = Ambient Humidity is between 45% - 65%

RED = Ambient Humidity is above 65%

If an Error code is displayed please refer to the table in the back of this manual.

Pressing the power button again will power the unit off.

MODE: Press this to cycle through Auto Mode / Continuous Mode / Sleep Mode

AUTO MODE: Both Fan speed and Humidity can be adjusted in this mode.

When the room humidity is higher than the selected humidity the fan and compressor will begin to operate after 3 seconds.

When the room humidity is below the set humidity the compressor and the fan will stop operating after a short delay.

CONTINUOUS MODE: The humidity is not adjustable in this mode. The unit will run continuously.

SLEEPING MODE: In this mode you can adjust the humidity only.

Press the button and after 10 seconds the indicators will turn dark and the fan speed will be set to low.

To cancel sleep mode press the mode button again

NOTE: In sleep mode no error codes will be displayed and the fan speed is not adjustable.

Humidity (HUM): This can be adjusted in Aromatic and sleep mode. Pressing the button will increase the set humidity by 5% increments, the unit will only cycle up through numbers.

To check the current room temperature press and hold the button and the display will show for 5 seconds.

TIMER BUTTON: The timer can be set for up to 24hrs.

Pressing the timer button will increase the timer by 1hr which will be shown on the display.

The timer when set will operate until time has elapsed and the unit will go into standby mode.

To turn the timer off press the Timer Button until “00” is displayed.

FAN SPEED: This can only be changed in Automatic mode. Pressing this will cycle the fan speed between High and Low.

LOCK: Press and hold this button and it will lock all button of from operation. To unlock press the button again, if the unit is turned off the child lock will be deactivated.

LCD PANEL

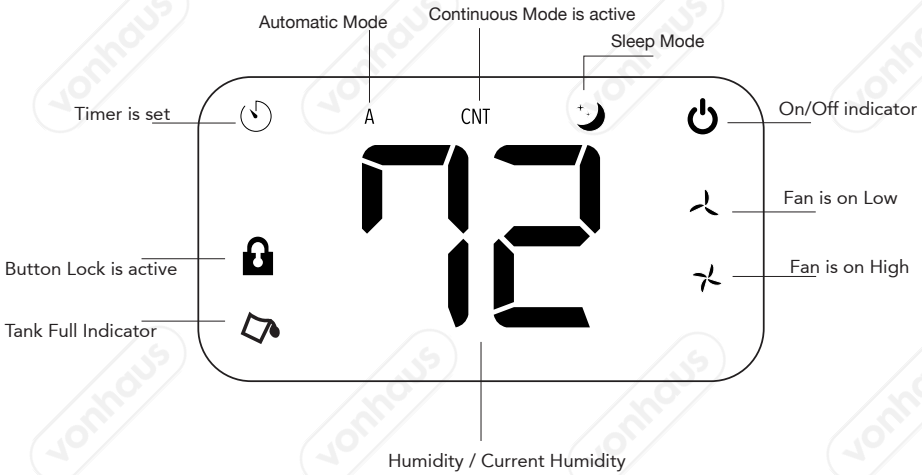

POSITIONING

When locating the Dehumidifier ensure its kept with at-least 30cm space all around the unit.

Ensure when in use all doors and windows are closed.

Do not force the castor wheels to move over carpet, or attempt to move the unit when it is in operation this may cause the tank to tip over and water to spill causing a hazardous environment.

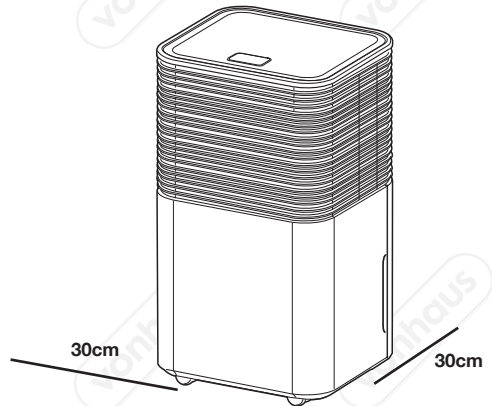

WATER TANK & WATER DISPOSAL

When the Water Tank is full the Indicator will display and the unit will stop automatically.

Unplug from the mains and remove the tank by holding the grips either side and pulling away.

NOTE: Do not set the tank down as the base is uneven.

Empty the tank and reinsert into the unit.

NOTE: Ensure the Water Tank is correctly installed as the unit will not operate.

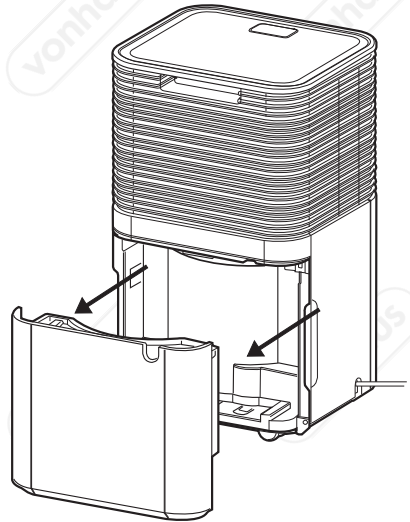

OVERFLOW PIPE

This unit is provided with a Overflow Pipe this is used when a large amount of water is going to be collected it will bypass the water tank and into a suitable bucket or drainage outlet.

To insert remove the tank and locate the tab and twist, place the Overflow Tube onto the outlet pipe.

Return the Tank into position for the unit to work and locate the pipe in a suitable place.

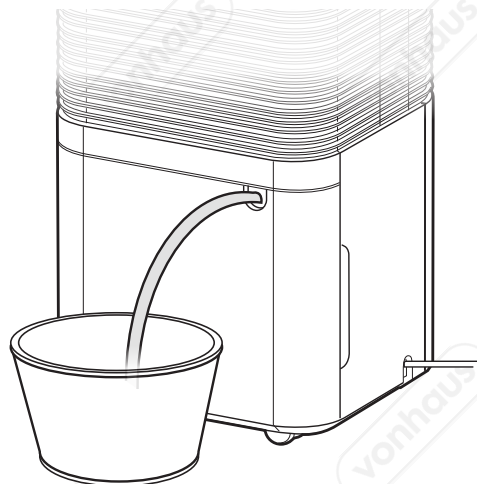

CLEANING THE FILTER (MONTHLY)

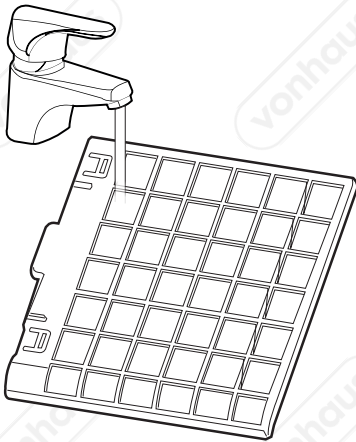
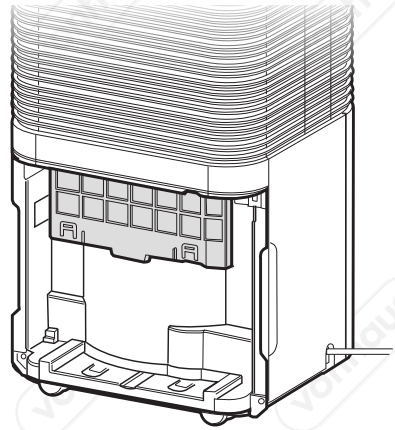
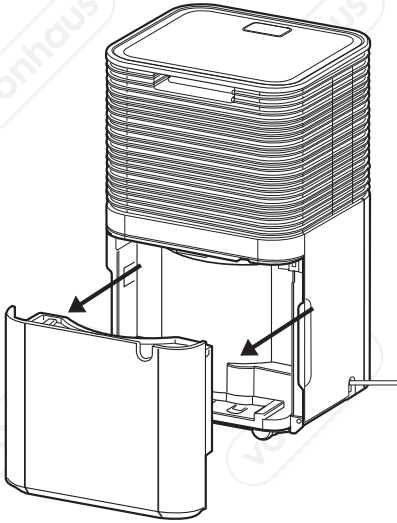

Clean debris from the filter using a soft bristle brush then with clean running water do not use any detergents or abrasive chemicals, rinse the filter thoroughly and leave to completely dry for 24 hours

CAUTION: Do not operate the unit without the filter in place and ensure it is completely dry before re-installing.

MAINTENANCE

1. Checks to the area

Prior to beginning work on systems containing flammable refrigerants, safety checks are necessary to ensure that the risk of ignition is minimized for repair to the refrigerating system, the following precautions shall be complied with prior to conducting work on the system.

Work procedure

Work shall be undertaken under a controlled procedure so as to minimize the risk of a flammable gas or vapour being present while the work is being performed.

2. General work area

All maintenance staff and others working in the local area shall be instructed on the nature of work being carried out. Work in confined spaces shall be avoided. The area around the workspace shall be sectioned off. Ensure that the conditions within the area have been made safe by control of flammable material.

3. Checking for presence of refrigerant

The area shall be checked with an appropriate refrigerant detector prior to and during work, to ensure the technician is aware of potentially flammable atmospheres. Ensure that the leak detection equipment being used is suitable for use with flammable refrigerant, i.e. non sparking, adequately sealed or intrinsically safe.

4. Presence of fire extinguisher

If any hot work is to be conducted on the refrigeration equipment or any associated parts, appropriate fire extinguishing equipment shall be available to hand. Have a dry powder or CO₂ fire extinguisher adjacent to the charging area.

5. No ignition sources

No person carrying out work in relation to a refrigerant system which involves exposing any pipe work that contains or has contained flammable refrigerant shall use any sources of ignition in such a manner that it may lead to the risk of fire or explosion. All possible ignition sources, including cigarette smoking, should be kept sufficiently far away from the site of installation, repairing, removing and disposal, during which flammable refrigerant can possibly be released to the surrounding space. Prior to work taking place, the area around the equipment is to be surveyed to make sure that there are no flammable hazards or ignition risks. "No Smoking" signs shall be displayed.

6. Ventilated area

Ensure that the area is in the open or that it is adequately ventilated before breaking into the system or conducting any hot work. A degree of ventilation shall continue during the period that the work is carried out. The ventilation should safely disperse any released refrigerant and preferably expel it externally into the atmosphere.

7. Checks to the refrigeration equipment

Where electrical components are being changed, they shall be fit for the purpose and to the correct specification. At all times the manufacturer's maintenance and service guidelines shall be followed. If in doubt consult the manufacturer's technical department for assistance.

The following checks shall be applied to installations using flammable refrigerants:

- the charge size in accordance with the room size within which the refrigerant containing parts are installed;
- the ventilation machinery and outlets are operating adequately and are not obstructed

8. Checks to electrical devices

Repair and maintenance to electrical components shall include initial safety checks and components inspection procedures. If a fault exists that could compromise safety, then no electrical supply shall be connected to the circuit until it is satisfactorily dealt with. If the fault cannot be corrected immediately but it is necessary to continue operation, an adequate temporary solution shall be used. This shall be reported to the owner of the equipment so all parties are advised.

Initial safety checks shall include:

- that capacitors are discharged: this shall be done in a safe manner to avoid possibility of sparking;
- that there no live electrical components and wiring are exposed while charging, recovering or purging the system;
- that there is continuity of earth bonding

9. Repairs to sealed components

During repairs to sealed components, all electrical supplies shall be disconnected from the equipment being worked upon prior to any removal of sealed covers, etc.

If it is absolutely necessary to have an electrical supply to equipment during servicing, then a permanently operating form of leak detection shall be located at the most critical point to warn of a potentially hazardous situation.

Particular attention shall be paid to the following to ensure that by working on electrical components, the casing is not altered in such a way that the level of protection is affected. This shall include damage to cables, excessive number of connections, terminals not made to original specification, damage to seals, incorrect fitting of glands, etc.

Ensure that apparatus is mounted securely.

Ensure that seals or sealing materials have not degraded such that they no longer serve the purpose of preventing the ingress of flammable atmospheres. Replacement parts shall be in accordance with the manufacturer's specifications.

NOTE: The use of silicon sealant may inhibit the effectiveness of some types of leak detection equipment. Intrinsically safe components do not have to be isolated prior to working on them.

10. Repair to intrinsically safe components

Do not apply any permanent inductive or capacitance loads to the circuit without ensuring that this will not exceed the permissible voltage and current permitted for the equipment in use.

Intrinsically components are the only types that can be worked on while live in the presence of a flammable atmosphere. The test apparatus shall be at the correct rating.

Replace components only with parts specified by manufacturer. Other parts may result in the ignition of refrigerant in the atmosphere from a leak.

11. Cabling

Check that cabling will not be subject to wear, corrosion, excessive pressure, vibration, sharp edges or any other adverse environmental effects. The check shall also take into account the effects of aging or continual vibration from sources such as compressors or fans.

12. Leakage detection for flammable refrigerants

Under no circumstances shall potential sources of ignition be used in the searching for or detection of refrigerant leaks. A halide torch (or any other detector using a naked flame) shall not be used.

13. Leak detection methods

The following leak detection methods are acceptable for systems containing flammable refrigerant.

Electronic leak detectors shall be used to detect flammable refrigerants, but the sensitivity may not be adequate, or may need recalibration (Detection equipment shall be calibrated in a refrigerant-free area.) Ensure that detector is not a potential source of ignition and is suitable for the refrigerant used.

Leak detection fluids are suitable for use with most refrigerants but the use of detergents containing chlorine shall be avoided as the chlorine may react with the refrigerant and corrode the copper pipe-work. If a leak is suspected, all naked flames shall be removed/extinguished.

If a leak of refrigerant is found which requires brazing, all of the refrigerant shall be recovered from the system. Oxygen free nitrogen (OFN) shall then be purged through the system both before and during the brazing process.

14. Removal and evacuation.

When breaking into the refrigerant circuit to make repairs- or for any other purpose-conventional procedures shall be used. However, it is important that best practice is followed since Flammability is a consideration. The following procedure shall be adhered to:

Remove refrigerant;

Purge the circuit with inert gas;

Evacuate;

Purge again with inert gas;

Open the circuit by cutting or brazing.

The refrigerant charge shall be recovered into the correct recovery cylinders. The system shall be "flushed" with OFN to render the unit safe. This process may need to be repeated several times. Compressed air or oxygen shall not be used for this task.

Flushing shall be achieved by breaking the vacuum in the system with OFN and continuing to fill until the working pressure is achieved, then venting to atmosphere, and finally pulling down to a vacuum. This process shall be repeated until no refrigerant is within the system. When the final OFN charge is used, the system shall be vented down to atmospheric pressure to enable work to take place.

This operation is absolutely vital if brazing operations on the pipework are to take place. Ensure that the outlet for the vacuum pump is not close to any ignition sources and there is ventilation available.

15. Refrigerant Charging procedures.

In addition to conventional charging procedures, the following requirements shall be followed.

- Ensure that contamination of different refrigerants does not occur when using charging equipment.
- Hoses or lines shall be as short as possible to minimize the amount of refrigerant contained in them.
- Cylinders shall be kept upright.
- Ensure that the refrigeration system is earthed prior to charging the system with refrigerant.
- Label the system when charging is complete (if not already).
- Extreme care shall be taken not to overfill the refrigeration system.

Prior to recharging the system, it shall be pressure tested with OFN. The system shall be leak tested on completion of charging but prior to commissioning. A follow up leak test shall be carried out prior to leaving the site.

16. Decommissioning

Before carrying out this procedure, it is essential that technician is completely familiar with the equipment and all its detail. It is recommended good practice that all refrigerants are recovered safely. Prior to the task being carried out, an oil and refrigerant sample shall be taken in case analysis is required prior to reuse of reclaimed refrigerant. It is essential that electrical power is available before the task is commenced.

Become familiar with the equipment and its operation.

b) Isolate system electrically.

c) Before attempting the procedure ensure that: mechanical handling equipment is available, if repaired, for handling refrigerant cylinders; all personal protective equipment is available and being used correctly; the recovery process is supervised at all times by a competent person; recovery equipment and cylinders conform to the appropriate standards.

d) Pump down refrigerant system, if possible.

e) if a vacuum is not possible, make a manifold so that refrigerant can be removed from various parts of the system.

f) Make sure that cylinder is situated on the scales before recovery takes place.

g) Start the recovery machine and operate in accordance with manufacturer's instructions.

h) Do not overfill cylinders (No more than 80% volume liquid charge).

i) Do not exceed the maximum working pressure of the cylinder, even temporarily.

j) When the cylinders have been filled correctly and the process completed, make sure that the cylinders and the equipment are removed from site promptly and all isolation valves on the equipment are closed off.

k) Recovered refrigerant shall not be charged into another refrigeration system unless it has been cleaned and checked.

17. Labelling

Equipment shall be labelled stating that it has been decommissioned and emptied of refrigerant. The label shall be dated and signed. Ensure that there are labels on the equipment stating the equipment contains flammable refrigerant.

18. Recovery

When removing refrigerant from a system, either for servicing or decommissioning, it is recommended good practice that all refrigerants are removed safely.

When transferring refrigerant into cylinders, ensure that only appropriate refrigerant recovery cylinders are employed. Ensure that the correct number of cylinders for holding the total system charge are available. All cylinders to be used are designed for the recovered refrigerant and labelled for that refrigerant (i.e. -special cylinders for the recovery of refrigerant). Cylinders shall be complete with pressure relief valve and associated shut-off valves in good working order. Empty recovery cylinders are evacuated and, if possible, cooled before recovery occurs.

The recovery equipment shall be in good working order with a set of instructions concerning the equipment that is at hand and shall be suitable for the recovery of flammable refrigerants.

In addition, a set of calibrated weighing scales shall be available and in good work order. Hoses shall be complete with leak-free disconnect couplings and in good condition.

Before using the recovery machine, check that it is in satisfactory working order, has been properly maintained

MAINTENANCE

and that any associated electrical components are sealed to prevent ignition in the event of a refrigerant release. Consult manufacturer if in doubt.

The recovered refrigerant shall be returned to the refrigerant supplier in the correct recovery cylinder, and the relevant Waste Transfer Note arranged. Do not mix refrigerants in recovery units and especially not in cylinders.

If compressors or compressor oils are to be removed, ensure that they have been evacuated to an acceptable level to make certain that flammable refrigerant does not remain within the lubricant. The evacuation process shall be carried out prior to returning the compressor to the suppliers. Only electric heating to the compressor body shall be employed to accelerate this process. When oil is drained from a system, it shall be carried out safely.

19. Transport of equipment containing flammable refrigerants.
Determined by local regulations.

20. Discarded appliances supplies flammable refrigerants.
See National Regulations.

21. Storage package (unsold) equipment
Storage package protection should be constructed such that mechanical damage to the equipment inside the package will not cause a leak of the refrigerant charge. The maximum number of pieces of equipment permitted to be stored together will be determined by local regulations.

TROUBLESHOOTING

No power to the unit	Water Tank has not been fully inserted. Power Cord may be damaged. Contact Customer services. Ensure Water Tank is not full before use.
Only small amounts of water being collected	Doors and windows may be open. Seal the room from external areas. Water Tank has not been fully inserted. Inlet blocked. Disconnect from mains outlet and remove blockage.
The unit leaks	Water Tank is full, empty tank and re-attach. The Unit is positioned on an uneven surface. Reposition to a suitable area.
Display is illuminated but unit does not operate.	The chosen RH level is higher than the RH level of the room. Reduce the setting.
Air Flow is weak.	Filter may be blocked. Remove, clean and replace.
Unit is noisy	The Unit is positioned on an uneven surface. Reposition to a suitable area. Inner fan may be damaged. Contact Customer Service for assistance.
No water is being collected	The Unit is set to a lower level than the humidity in the room. Temperature too low for water extraction. Increase the temperature of the room. Check the Unit for blockages. Ensure the Unit is not too close to walls or furniture.
The unit stops regularly	The Unit is defrosting, allow the Unit to automatically defrost. Increase the temperature of the room if this repeats often.
Ice is forming	Settings are too high. Reduce the settings
Hot or cold air is being produced	This is completely normal when the Unit is dehumidifying as it absorbs humid air from the room and freezes it to reduce the humidity.

ERROR CODES

CODE	ERROR	SOLUTION
E0	PCB or wiring malfunction	Contact DOMU customer service
E2	Humidity Sensor	Contact DOMU customer service.
LO	Room Humidity is below 20%	The unit will power off for self protection.
HI	Room Humidity is above 90%	
CL	Low Temperature Protection the room temperature is below 5°C	
CH	High Temperature protection the room temperature is higher than 38°C	



EN

DISPOSAL INFORMATION Please recycle where facilities exist. Check with your local authority for recycling advice.

WARRANTY To register your product and find out if you qualify for a free extended warranty please go to www.vonhaus.com/warranty.

Please retain a proof of purchase receipt or statement as proof of the purchase date. The warranty only applies if the product is used solely in the manner indicated in the warnings page of this manual, and all other instructions have been followed accurately. Any abuse of the product or the manner in which it is used will invalidate the warranty. Returned goods will not be accepted unless re-packaged in its original packaging and accompanied by a relevant and completed returns form. This does not affect your statutory rights. No rights are given under this warranty to a person acquiring the appliance second-hand or for commercial or communal use.

COPYRIGHT All material in this instruction manual are copyrighted by DOMU Brands. Any unauthorised use may violate worldwide copyright, trademark, and other laws.

THANK YOU

Thank you for purchasing your product/appliance. Should you require further assistance with your purchase, you can contact us at support@domu.co.uk

VonHaus is a registered trademark of DOMU Brands Ltd.
Made in China for DOMU Brands. M24 2RW.